

#W724

HAFCO WOODMASTER
PS-3200 PANEL SAW

ASSEMBLY
AND
SET UP
INSTRUCTIONS



Assembly instructions

Before un-crating the machine or the table assembly, please ensure the serial numbers on the 2 x crates correspond with each other.

If not please contact the point of purchase and advise them serial numbers supplied

CAUTION

Must be taken when un-crating of sharp edges of sheet metal corner supports and nails

Remove lid off the large main saw box (1 of 2) and then the sides one by one

Remove the lid of the long box (2 off 2)

Open rear blue door of the main saw stand to gain access and remove the cardboard box with blades operation instructions, tools and other small parts and accessories.

Remove all other packing and accessories.

Read safety and operation instructions supplied

Position machine

Remove machine off wooden skid and Position machine in final position

Please note the machine needs a working area of 7200mm x 5000mm with an additional 500mm safety zone around all sides of this area to avoid crush zones

(total area 8200mm x 6000mm)

DO NOT Put power to machine it at this stage

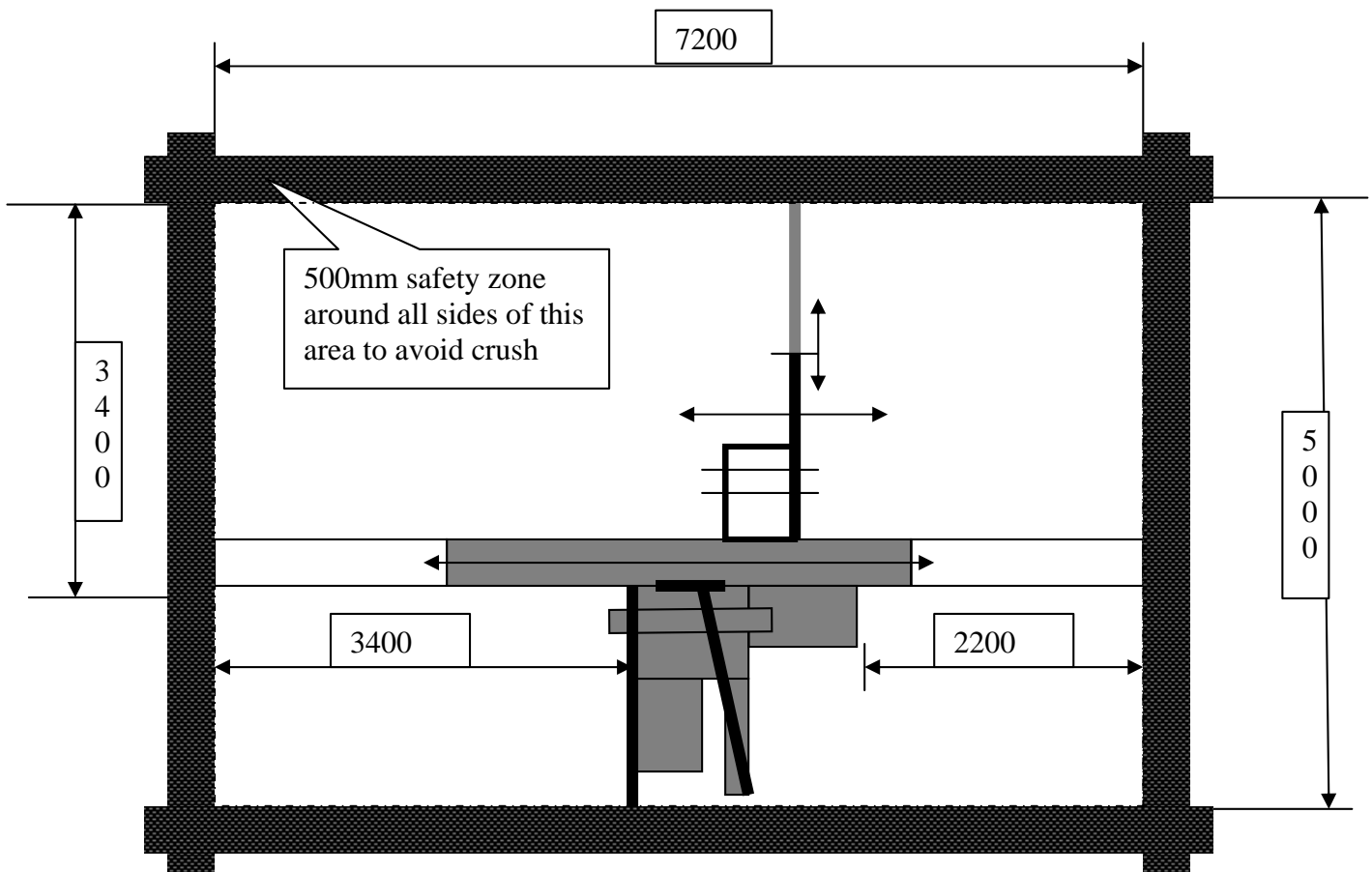

Fit sliding table assembly

Unpack the long box of all extra pieces leaving sliding table assembly in crate.

Remove the 4 sides of the crate

With the aid of a forklift remove wrapped sliding table assembly by sliding onto fork tines

Carefully cut along length of table and remove packaging.

Check table sliding lock lever (RH front of table assembly when up correct way) is in the locked position!

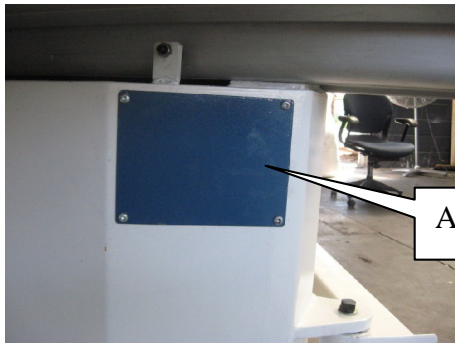

Access cover

Table lock lever in lock position

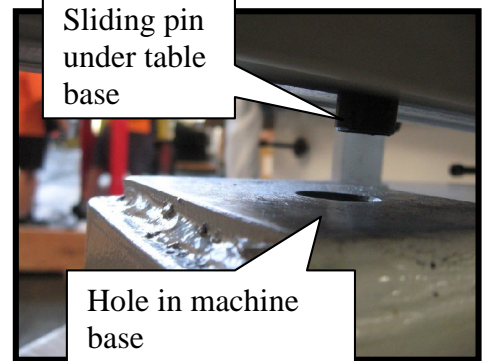

Sliding pin under table base

Hole in machine base

Remove the access cover off the right hand rear of saw bench and open up electrical cabinet. (Ensure machine is not connected to power)

Position fork in front of saw bench and with assistance roll over table assembly onto its top.

Lift off and position table on saw body locating 3 x sliding pins in the 3 x holes on table base.

Screw in and finger tighten only each end attachment bolt.

Being careful not to disturb any electrical wiring.

Table base assembly can now be pushed Left or Right to position it in the correct place

NB the positioning of the table is to finish as shown

(720 mm from Right hand side of machine base)

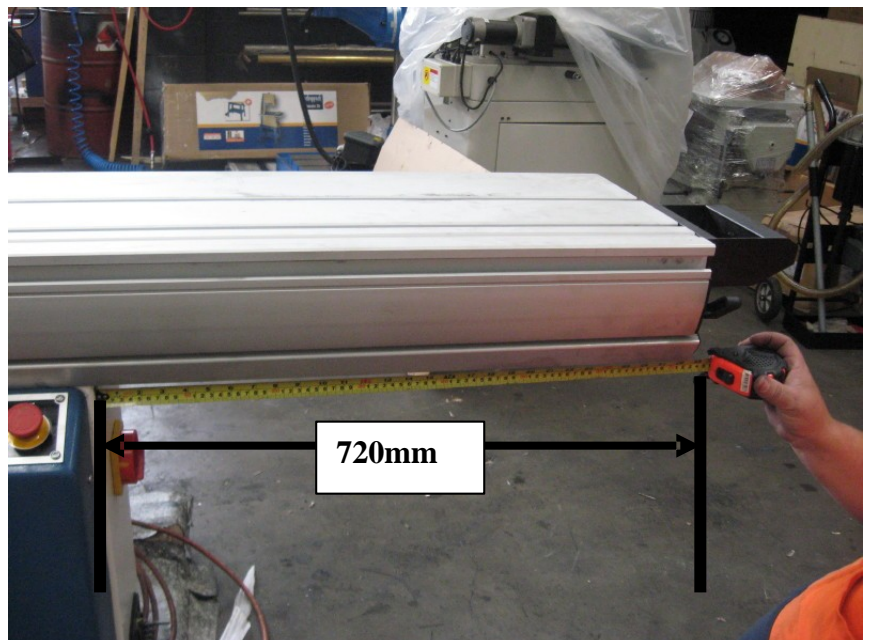

720mm

Tighten the 2 x end screws with 10mm allen key supplied in tool bundle

Ensuring first that the table assembly is slid back to sit on the 2 x adjustable table setting screws that have been factory set.

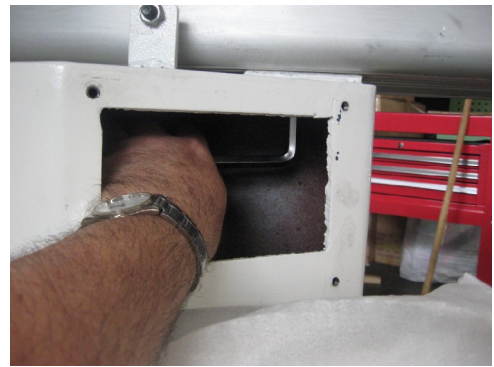
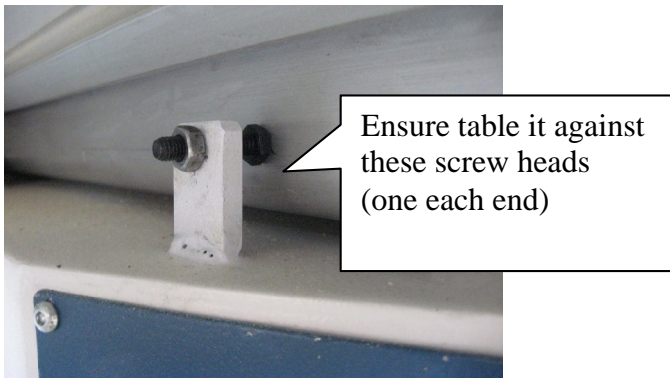

When these 2 bolts are tight unlock sliding table and slide table all the way to the right (table should be 40-45mm as shown)

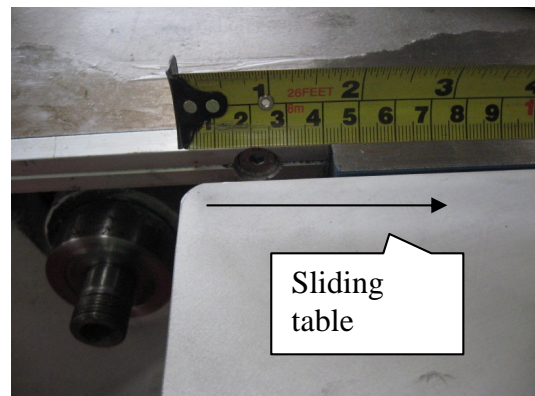

With table in this position

This will give you access to the hole for the middle table attachment screw hole fit screw up and under into hole and tighten it firmly

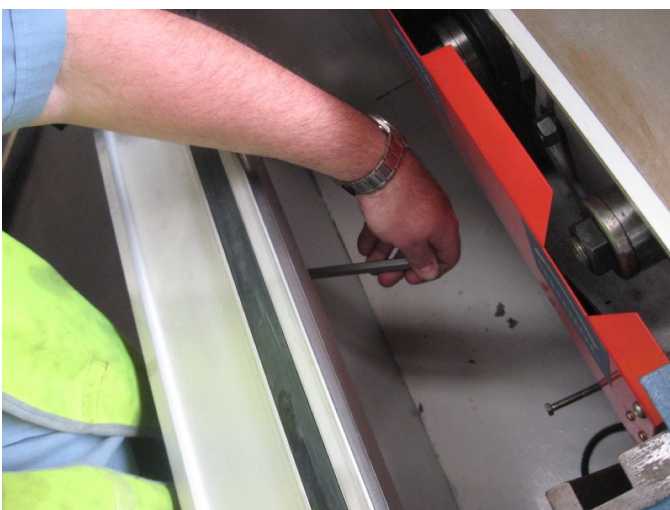

Check table slides freely full travel both directions.

Set table back in centre and lock table lever

Refit access cover and close electrical cabinet.

Fit Overhead Guard Assembly

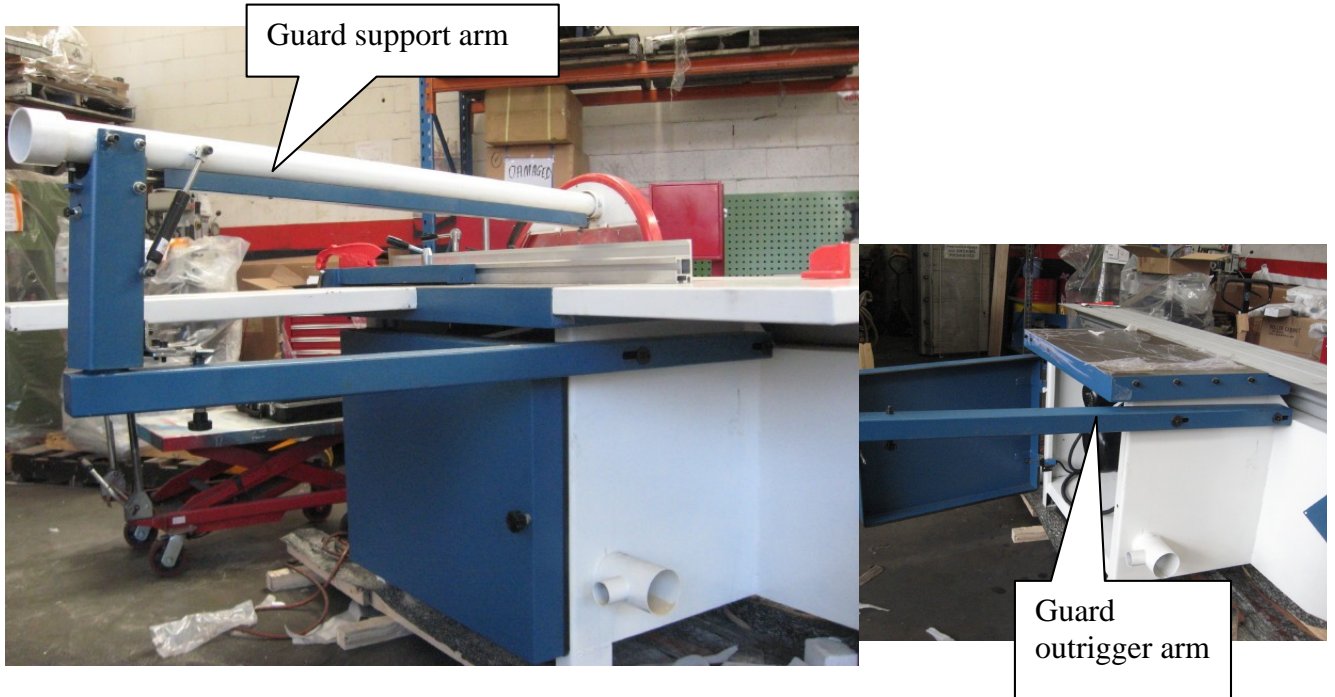

Remove the two bolts out of main base LH rear side (Looking from the front of machine)
NB; there are locknuts inside base that need removing first.

Fit guard outrigger arm to machine and nip up 2 x screws (Adjustment is needed later)

Fit guard support arm onto spigot of arm and locate spring loaded pin into Swivel location engagement bracket.

Bracket may need adjusting to suit! Up/down and in out adjust up/down positioning of bracket so when location pin is up in hole it is flush with top of plate!

(Further adjustment may be needed when setting blade guard over blade)

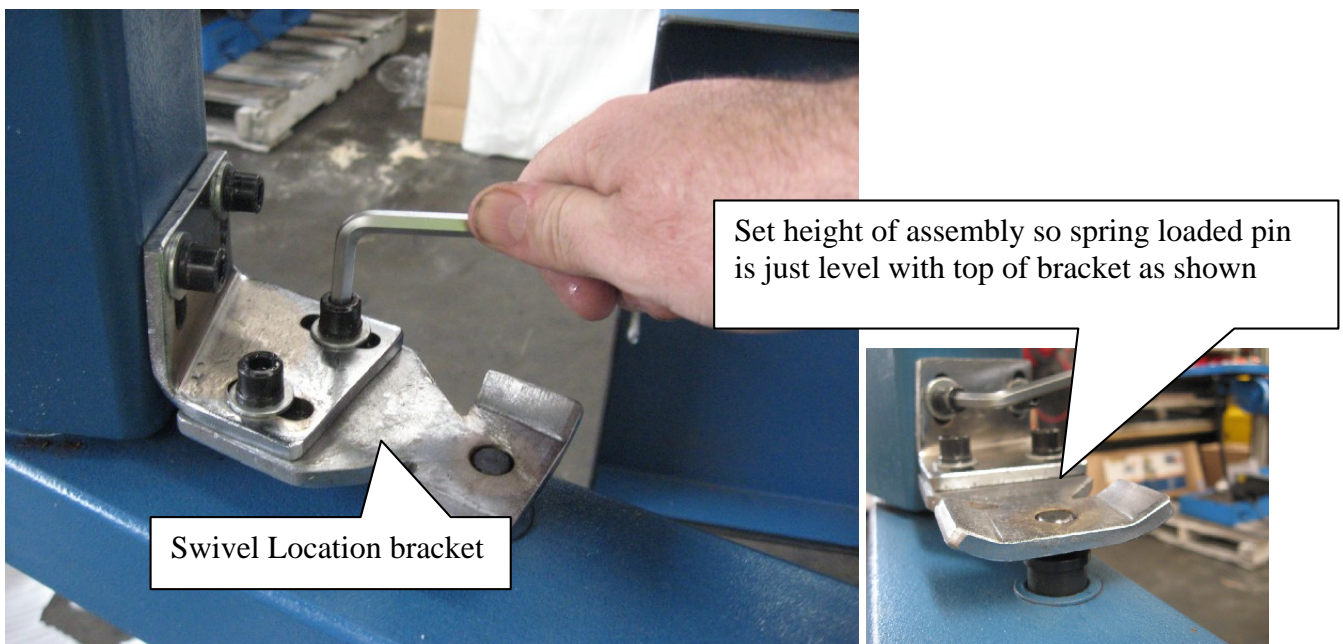

Remove the 2 x screws out of the pin that runs through the end of guard support arm.

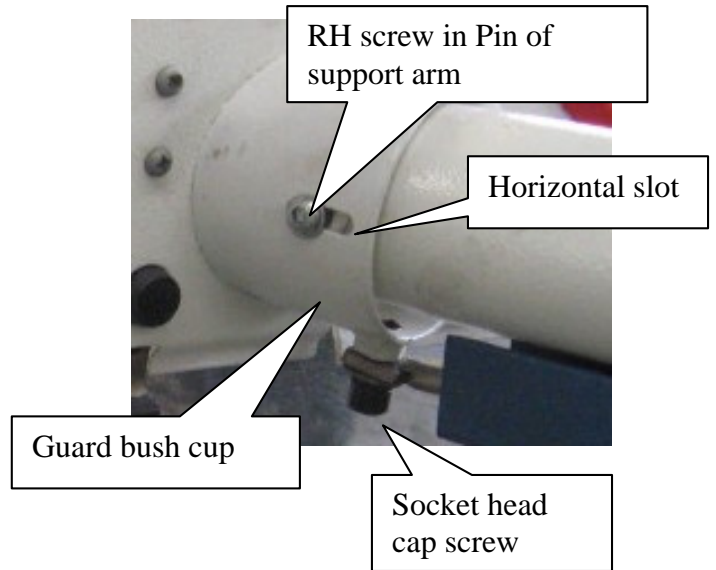

Remove the blue fiberglass 45degree cutting shield out of guard assembly if fitted.

Remove socket head cap screw out of guard bush cup

Fit the guard onto the end of the pipe and refit and fasten tightly the 2 x screws for the pin and the socket head cap screw for the positioning rod

Fit 90 degree Standard Clear Perspex rear guard piece into overhead guard

Positioning and adjustment of overhead guard

The guard will now need adjusting to fit safely and correctly.

Swing guard assembly over blade position and lock in place if not already done.

Firstly adjust the guard so it is over the blade opening, central to the blade opening and parallel to the blade slot.

Do this by adjustment of the “swivel location bracket”, the “guard attachment pin” (horizontal and vertical slots).

And the main guard outrigger arm were it is bolted to stand in the adjustable slots to bring assembly over the slot

Guard should be adjusted so the blade slot in table is central between the guards guide rollers.



Also the guard needs to be adjusted 90 deg to table

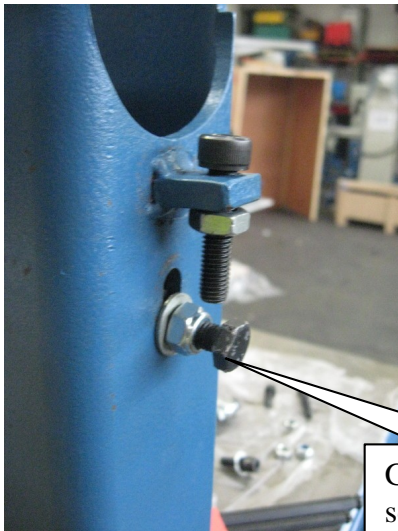

Adjustment is made by unlocking the Nyloc nut on the rear adjustment screw and turning the screw in or out.

Guard tilt adjustment screw



When guard is 90 degrees lock Nyloc in place
NB if there is insufficient adjustment available more adjustment can be obtained by adjusting the draw bar turnbuckle under the sheet metal guard running underside of the guard arm!



Fit the dust collector hose from the rear of the guard arm to the fitting on the side of the 100mm lower stand outlet. Top of hose fits into overhead arm (Hold in with Duct tape) And the bottom of hose fits on with hose clamp supplied.



Check guard is set correctly and readjust if needed.

Fit rear table extension (560 x 600) to LH side

This is held on with 4 x socket head cap screws and can be adjusted up from any fall by screwing in the 4 x lower cap screws as needed and hitting the table were it is bolted on with a soft hammer up and down

Sit a straight edge across the main table and sliding table to get extension table were needed



Fit Rear table extension (500 x 900) to rear of main table

This is held on with 4 x socket head cap screws and can be adjusted up from any fall by screwing in the 4 x lower cap screws as needed and hitting the table were it is bolted on with a soft hammer up and down

Sit a straight edge across the main table and sliding table to get extension table were needed

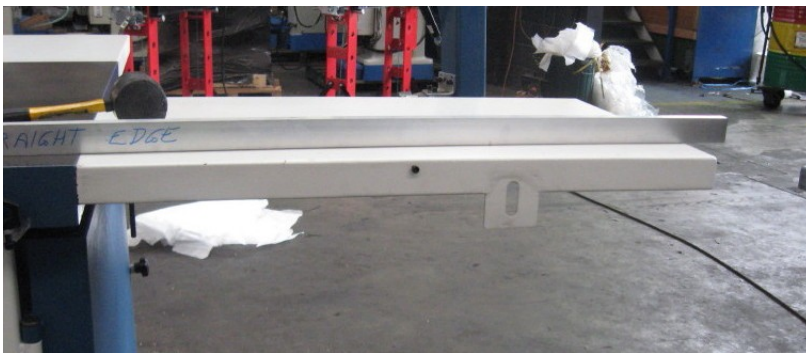

Fit sliding rear fence

Swivel blade guard out of the way.

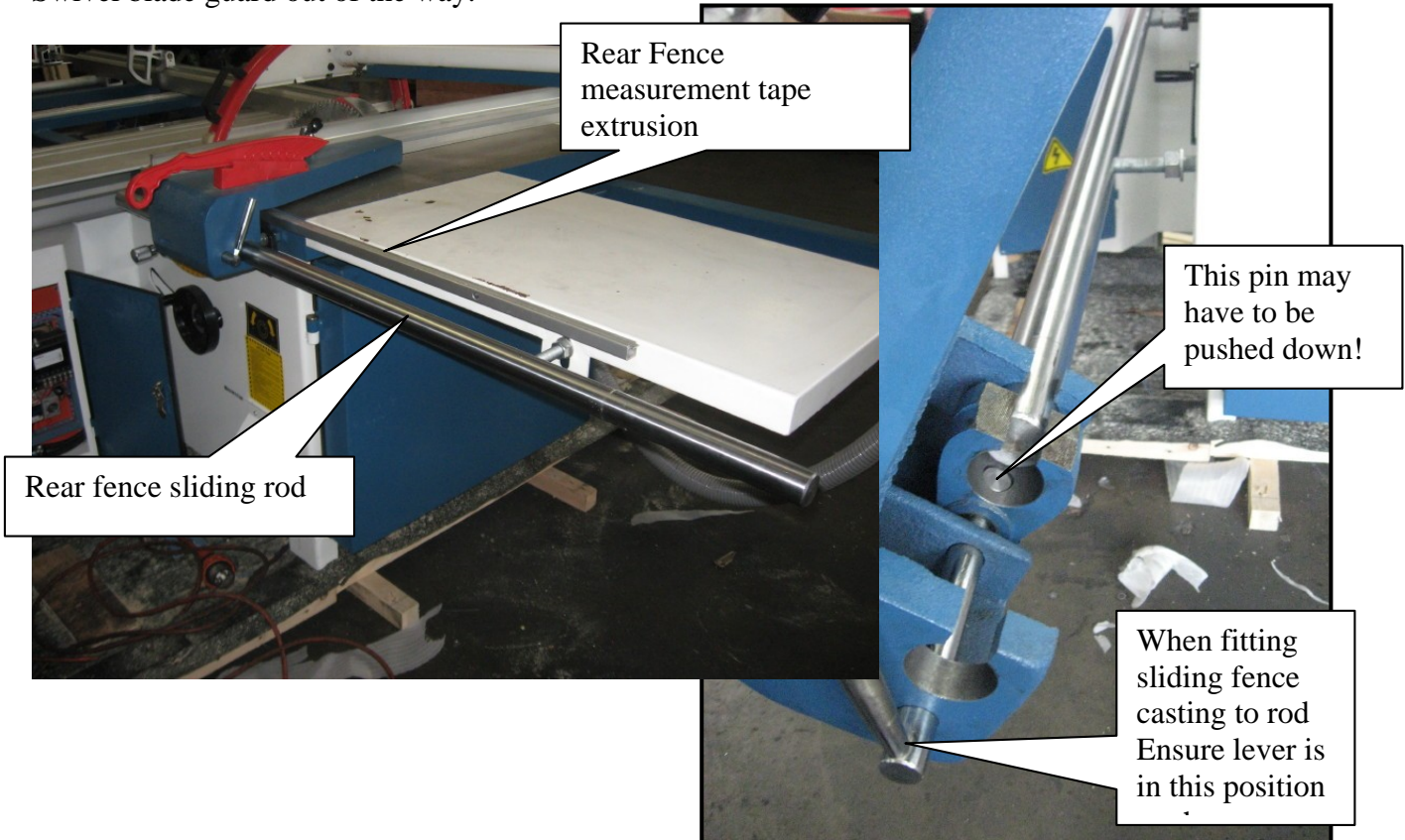

Remove the first nut of each of the 3 studs coming off the rear fence sliding rod

Leaving 2 thin locknuts locked together on 2 of the studs and 1 x thicker nut on the other with one washer. Wind this nut all the way towards rod.

Insert the 3 studs into the 3 holes.

Carefully with assistance and concentrating on the front 2 studs going into the cast mounting brackets.

Fit a washer and nut on to each and screw nut on until stud can be seen just coming out of each nut Pushing the studs down onto the adjustment bolts in the slots, tighten up these 2 nuts

Carefully slide on the fence sliding casting

Note the position of lock lever. The pin may have to be pushed in to slide lock clamp over shaft

Slide the casting up to the main table

Fit the fence extrusion onto the sliding casting, lock in place and then slide the fence assembly up approximately 100mm off the aluminum insert in the blade gap.

Measuring as shown by the 2 arrows

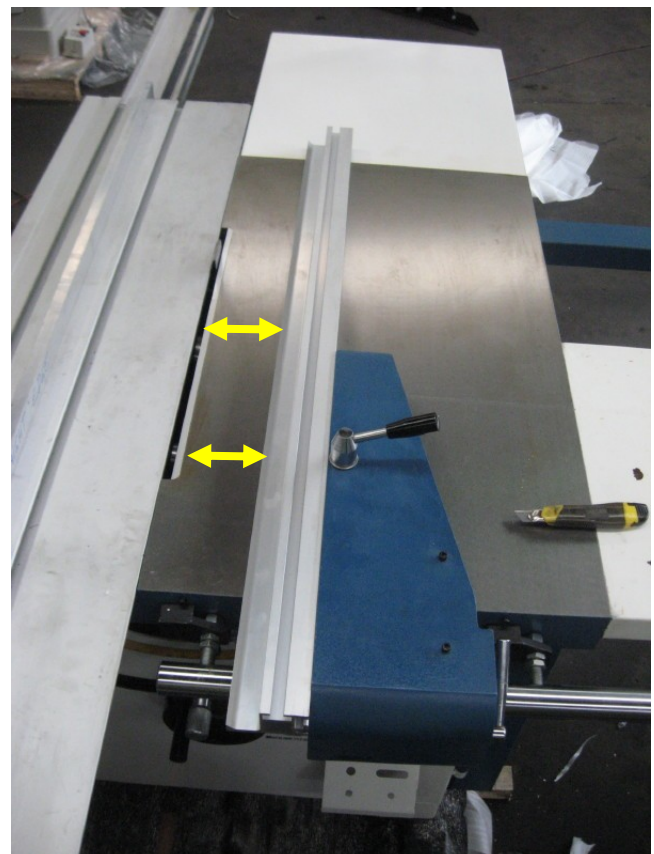

The fence can now be adjusted parallel with this insert if needed by adjusting the 2 inner stud nuts of the fence rod as needed. Ensure the rod is always pulled down on the adjustment screws and lock the second lock nuts tight when setting is achieved

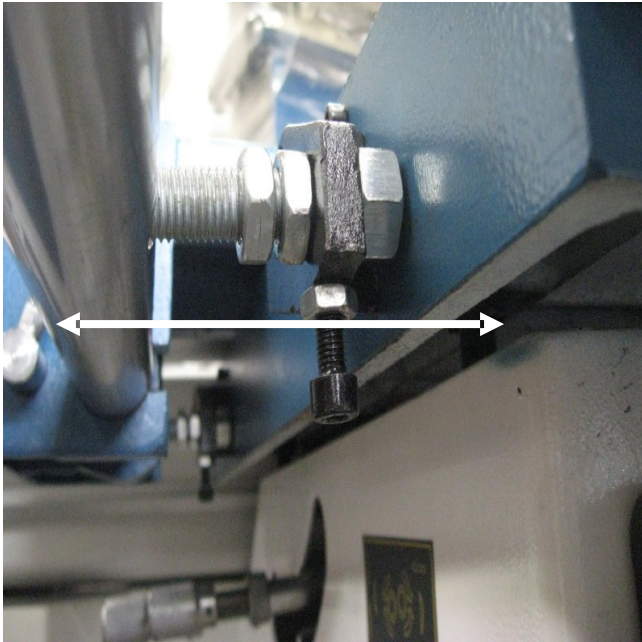

The aluminum fence level and parallel can be adjusted if needed by loosening and turning the cams in the sliding casting that the fence slips on.

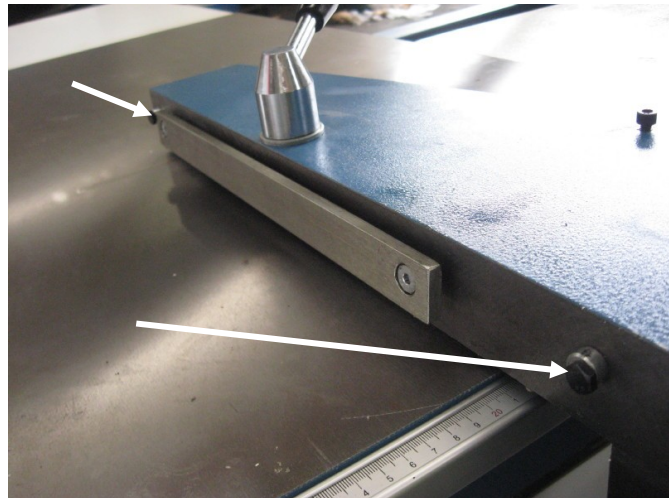

Now carefully, sliding the fence assembly out off the main table and onto the sheet metal outrigger table, the level of the outrigger table can be adjusted as needed up or down so the roller of the sliding fence casting transitions smoothly over the join.

The outrigger table may also need adjusting of its tilt as well to ensure the fence doesn't scrape.

With the fence now all the way out, its parallelism with the blade slot can be rechecked as well. While fitting a washer and nut onto the 3rd outer stud, the rod can be slightly pushed in or out while being locked in place to ensure fence is still parallel to blade slot.

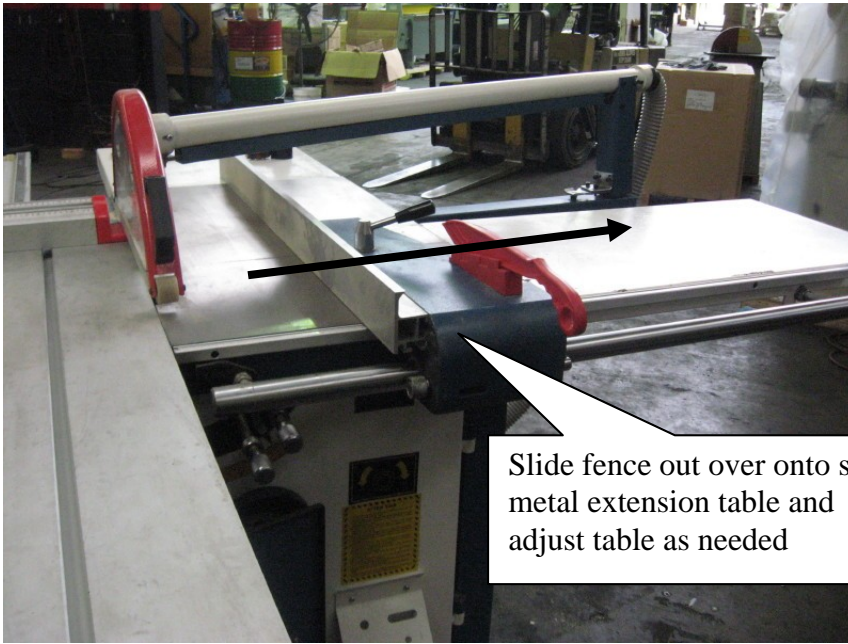

Fit fence measure

Remove the 3 x M6 socket heads cap screws from above the fence rod and fit the RHS measuring assembly
(This will need setting later when blade is put on machine)

Fit Push stick mount onto top of sliding casting as shown

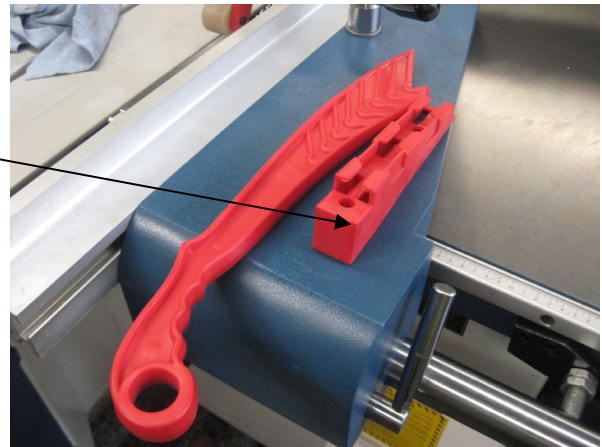

Fit sliding table outrigger frame

Swing out outrigger pivot arm.

Remove rubber stopper of the end of outrigger extension arm and carefully insert arm with location bolt sticking up, into outrigger assembly. When all the way through refit rubber stopper tightly.

Carefully unwrap the outrigger table being sure to find an alloy block and 2 x ratchet handles. Put aside for later

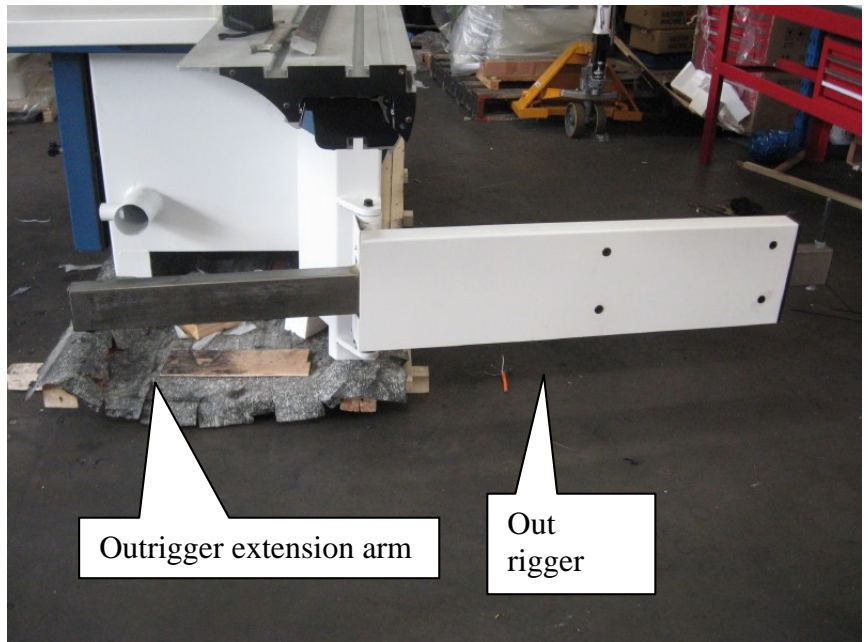

Ensuring main sliding table is in a locked position, fit the sliding carriage onto the location bolt of the outrigger extension arm at the same time sliding the table hooks in from the front end of the sliding table.



Slide assemble to the middle of the sliding table and lock in position.

Using a straight edge across the sliding table over to the roller on the outrigger table check and adjust height as needed by undoing the lock nuts on the location pin and moving up or down as needed. Ensure nuts are all locked when done.

Adjust and relock nuts, top and bottom as needed

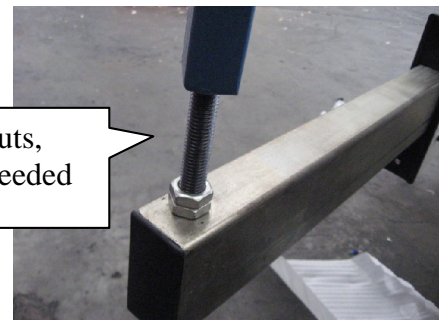

Fit front fence

Sit aluminum riser block on outrigger as shown

Sit fence on its side as shown and align the 2 x locating pins front and back and the middle lock down bolt as shown.

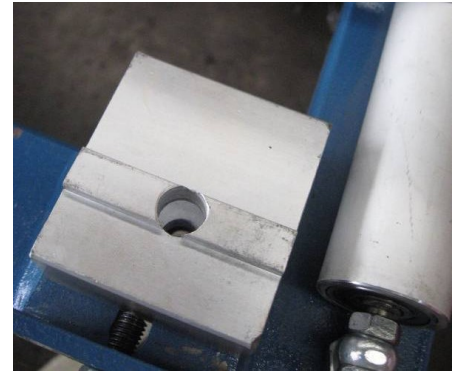

Tilt fence over the right way locating the 3 in perspective holes.

Screw in 1 ratchet handle to front pivot pin.

Holding alloy riser block up onto fence, swing fence to the rear of machine and fit large washer and locking Knob onto middle stud. Swing fence back and fit other ratchet handle to outer locating pin.

Ensuring fence is pulled back against stop,
(slid away from blade and swung to be on 90 degrees)
lock it in place.

Fit one of the sliding stops to the extension block. Push all the way to the pin in the block and lock in place.

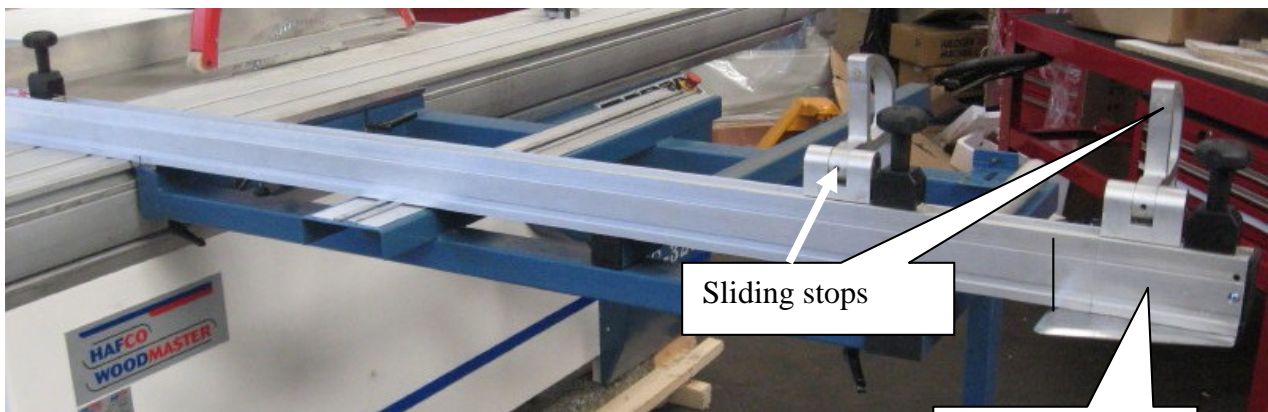

Fence extension block

Fit a smaller magnifier line to it
 (3 x magnifying lines found in blade box)

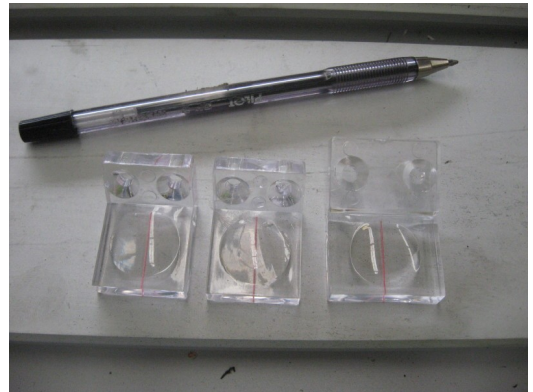
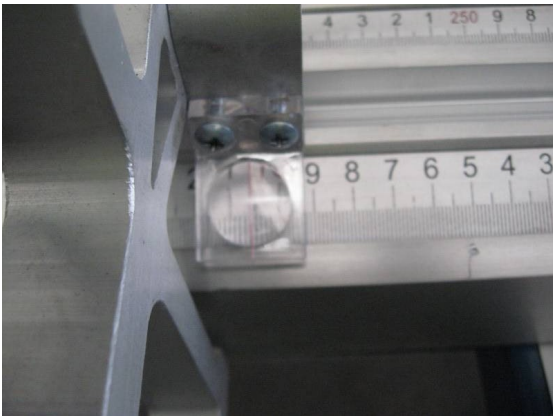

Fit the other sliding stop to the main arm and screw on a small magnifying line



Fit magnifying sight (large one) to fence extension arm

Fit thigh pushing bar
 Remove plastic plug from end of tube that has drilled hole in. Remove 2 x nuts off screw in frame and refit as shown with 2 x lock nuts locked together and RHS can still swing freely
 Refit plastic end cap

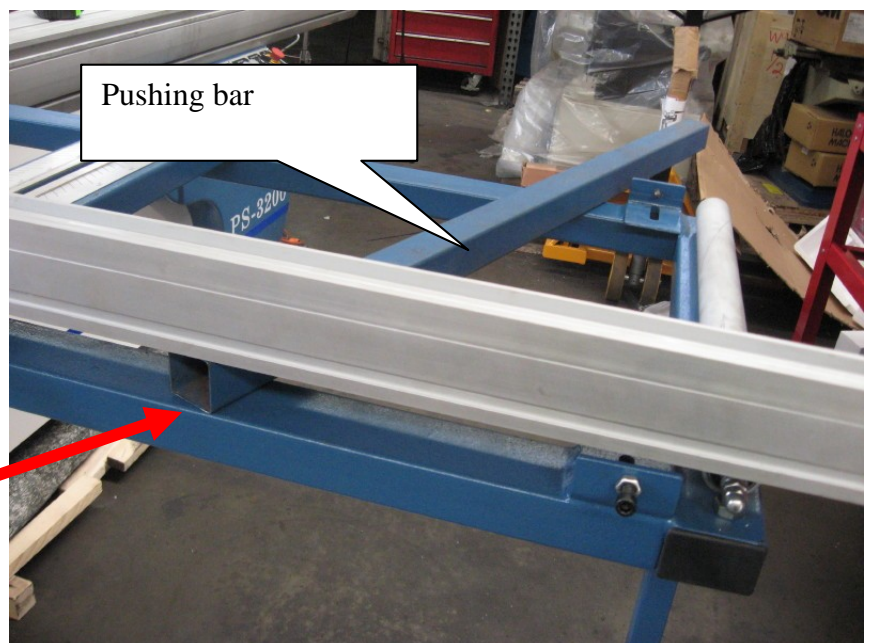

Fit Right hand table extension guard as shown



Fit work clamp
Slide onto end of table and lock in place when needed.

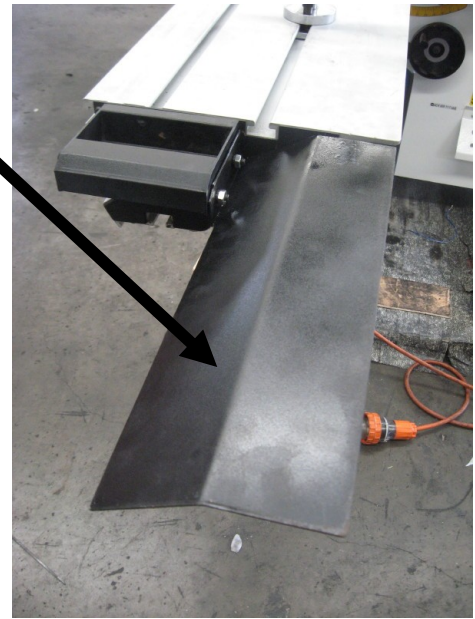

Fit blades

Extreme care must be taken due to sharp blade teeth.

Ensuring machine is not connected to power

Slide table assembly all the way back to gain access to blade area

Pull lower blade guard assemble open

NB blade nuts undo the direction the blade spins in use. Main blade Clockwise Scribe blade Anti-Clockwise) (see pic)

Fitting scribe blade (turns anti-clockwise in use)

With large double ended spanner and 10mm allen key supplied fit key in spindle hole and undo nut anti-clockwise. Remove nut and support flange completely

Fit scribe blade then flange and nut, do up nut tightly using opposite forces against allen key

Fit main blade

(turns clockwise in use)

With large double ended spanner and 10mm allen key supplied fit key in spindle hole and undo nut clockwise. Remove nut and support flange completely
Fit main blade then flange ensuring both are sitting correctly on the 2 x locating pins then screw on nut do up nut tightly using opposite forces against allen key.

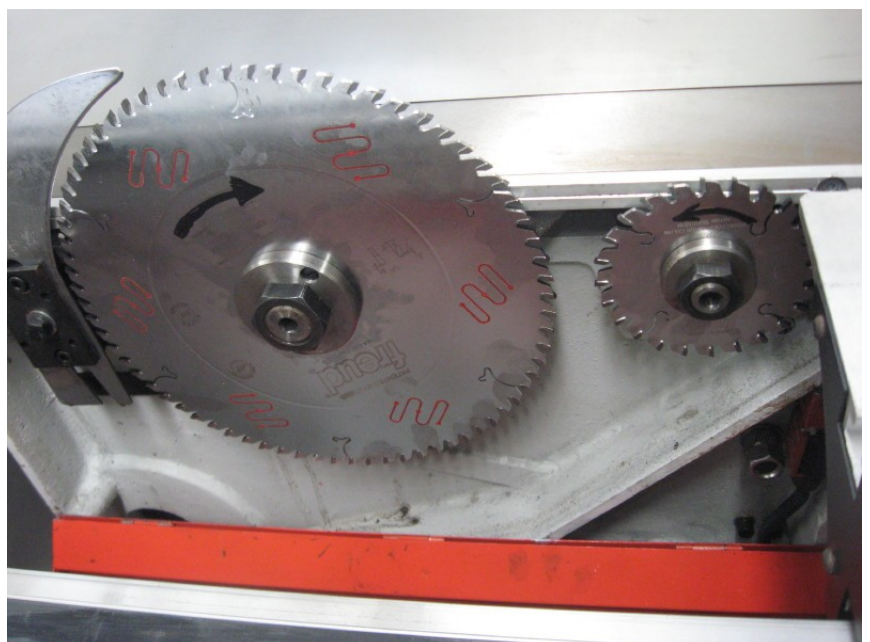

Setting height of Riving Knife

The riving knife height can now be set (just under height of blade cut)

Put a bit of scrap wood behind main blade and wind blade up level with the top of it.

Undo riving knife lock bolt and move riving knife as needed to be just under level of wood

Lock bolt tight

Lift up lower blade guard and push back closed

Wind main blade all the way down



Setting measurement tapes on outrigger fence

Ensuring machine is not connected to power

Line outrigger table fence up with main blade (lock table in position)

Set rear measurement tape of fence

Slide out extension arm and measure with a separate tape measure, 200cm from the saw blade to the flip over stop on the end of the extension arm. Lock extension in place
The measurement tape in the aluminum extrusion can now be set to 200cm under the magnifier line by unscrewing small knob under the fence, sliding the tape in the slot as needed and locking the knob again

(NB ends of metal tape in the slot may have to be trimmed to suit)

Final adjustment can be done after taking a test cut and re-measuring at a later date

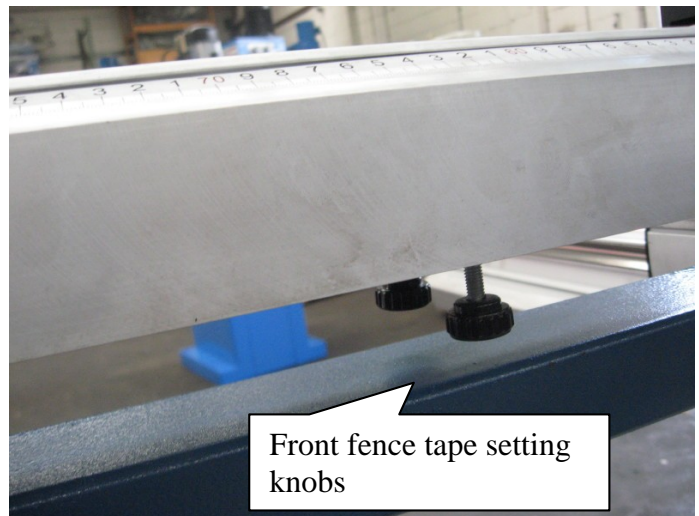

Ensuring machine is not connected to power

Set front measurement tape of fence

Flip over a length stop measure with a separate tape measure, 100cm from the saw blade to the flip over stop on the fence.

The measurement tape in the aluminum extrusion can now be set to 100cm under the magnifier line by unscrewing small knob under the fence, sliding the tape in the slot as needed and locking the knob again

(NB ends of metal tape in the slot may have to be trimmed to suit)

Final adjustment can be done after taking a test cut and re-measuring at a later date

Ensuring machine is not connected to power

Set measurement of tape on rear fence

Bring the fence 100mm away from blade measuring it with a tape measure as shown.
Loosen the tape adjustment screw found under the RH end on the alloy extrusion the tape is set in
Slide the tape in the extrusion to show 100mm under the fence and then tighten the screw again.
Final adjustment can be done after taking a test cut and re-measuring at a later date

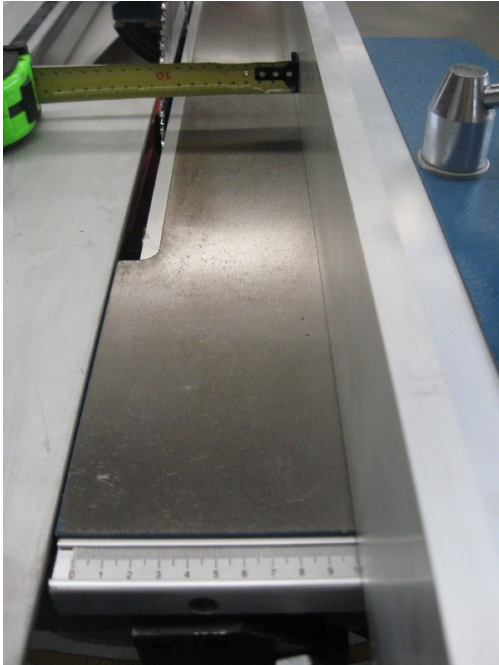

Setting of overhead guard

The blade guard **MUST** always be in place over the blades when machine is in use
Final adjustment of positioning of the guard may need to be done again as per directions explained previously.
The height of the blade guard must always be set with the bottom of the guard down to the thickness of the material being cut.
This is adjusted by releasing the lock nut on the rear upright of the blade arm assembly and turning the socket head cap screw as needed
“ UP (anti clockwise) to move the guard closer to the table and DOWN (clockwise) to lift the blade guard up higher
When set correctly ensure the screw is locked in place by locking the nut.

Always ensure the rear cover of the blade guard is fitted correctly to suit the cut being used
Clear straight one for 90 deg cuts
Blue fiberglass one for cuts to 45 degrees

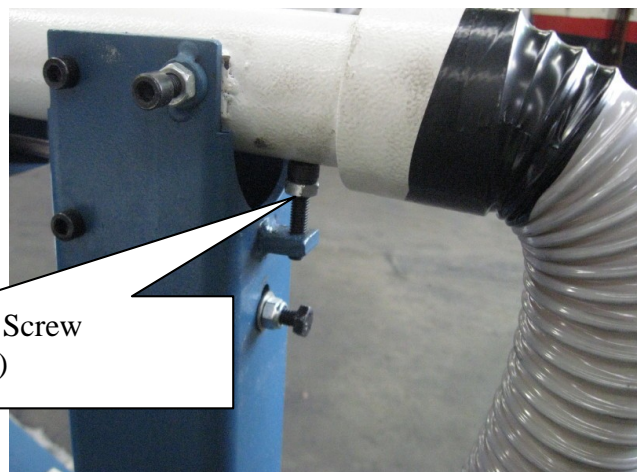

Blade Guard height Setting Screw
(Shown with lock nut loose)

Putting power to machine and testing operation

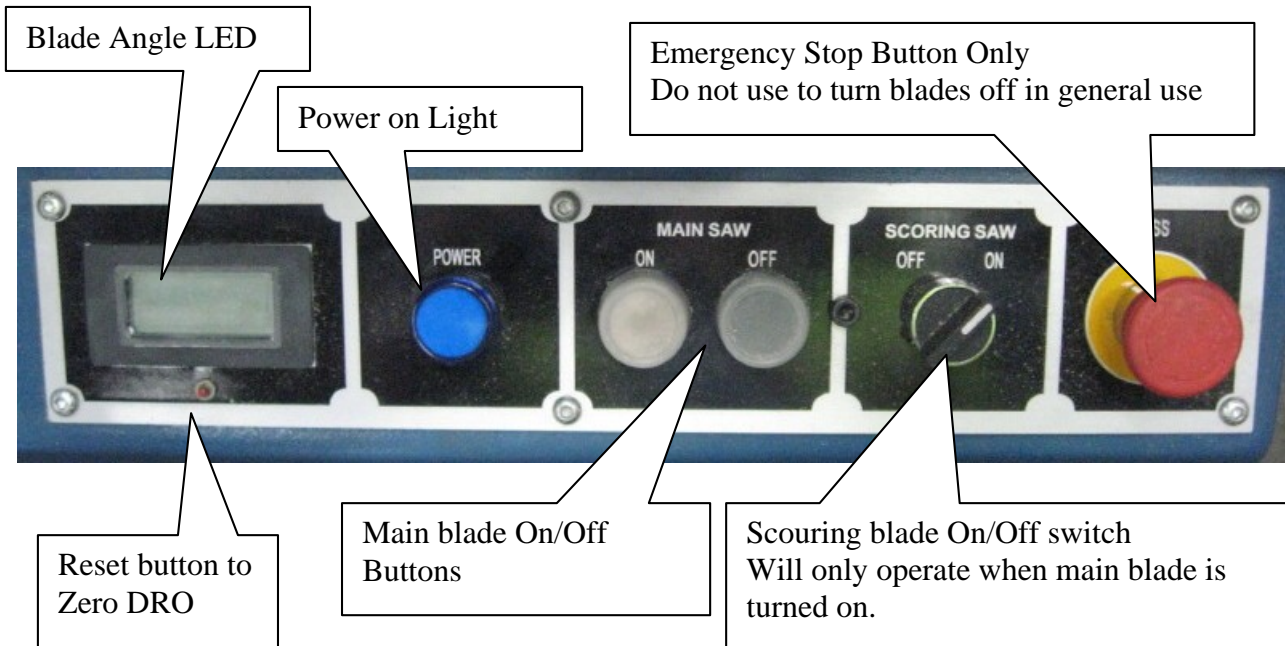

Swing the blade guard over the blade.
Wind blade fully up
Wind blade to be on the 90 degree stop.

Ensuring the isolation switch on the RH side of the machine is in the off position ("0"), the emergency stop on the front panel is depressed and the scouring saw switch in the "OFF" position, Have a fully licensed Electrician put power to the machine.

Turn the isolation switch to "ON" ("1") position and release the emergency stop button.

Check correct rotational direction of them main blade by quickly pressing the MAIN SAW "ON" Button and straight after that main saw OFF Button
The main blade should spin clockwise.
If it does not, have licensed electrician reverse the phase direction of the power to the machine.

Retest as above and when all is correct, switch on the SCOURER BLADE,
This should go anticlockwise,
(NB the Scouring blade will not operate unless the main blade is switched on)

The "Blade Angle" LED may be flashing. If so press and HOLD down the small red "reset" button under the LED panel for 10 to 20 seconds.

LED will set itself to "00.00"

NB: the resetting of the LED may have to be done if the Emergency stop is pressed or there is a power cut when the blade is not on 90 degree cut

Always wind blade to 90 deg before resetting to "00.00"

Blade guard

Please note the saw is supplied with 2 different rear covers for the blade guard.

A 45 degree one that must be fitted when tilting the blade and one that is for straight cutting
Ensure the correct guard is used at all times.

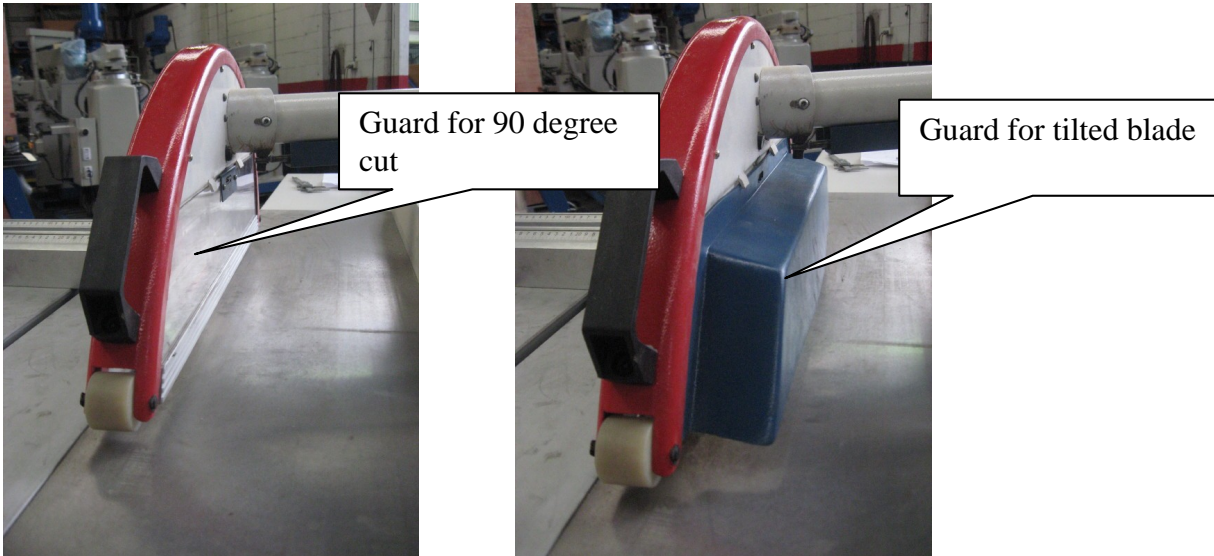

Setting scouring blade.

The Scouring (or Scriber) blade will need to be set when used

Left and right adjustment is done by the Right hand Screw

Up and Down adjustment is done by the Left hand Screw

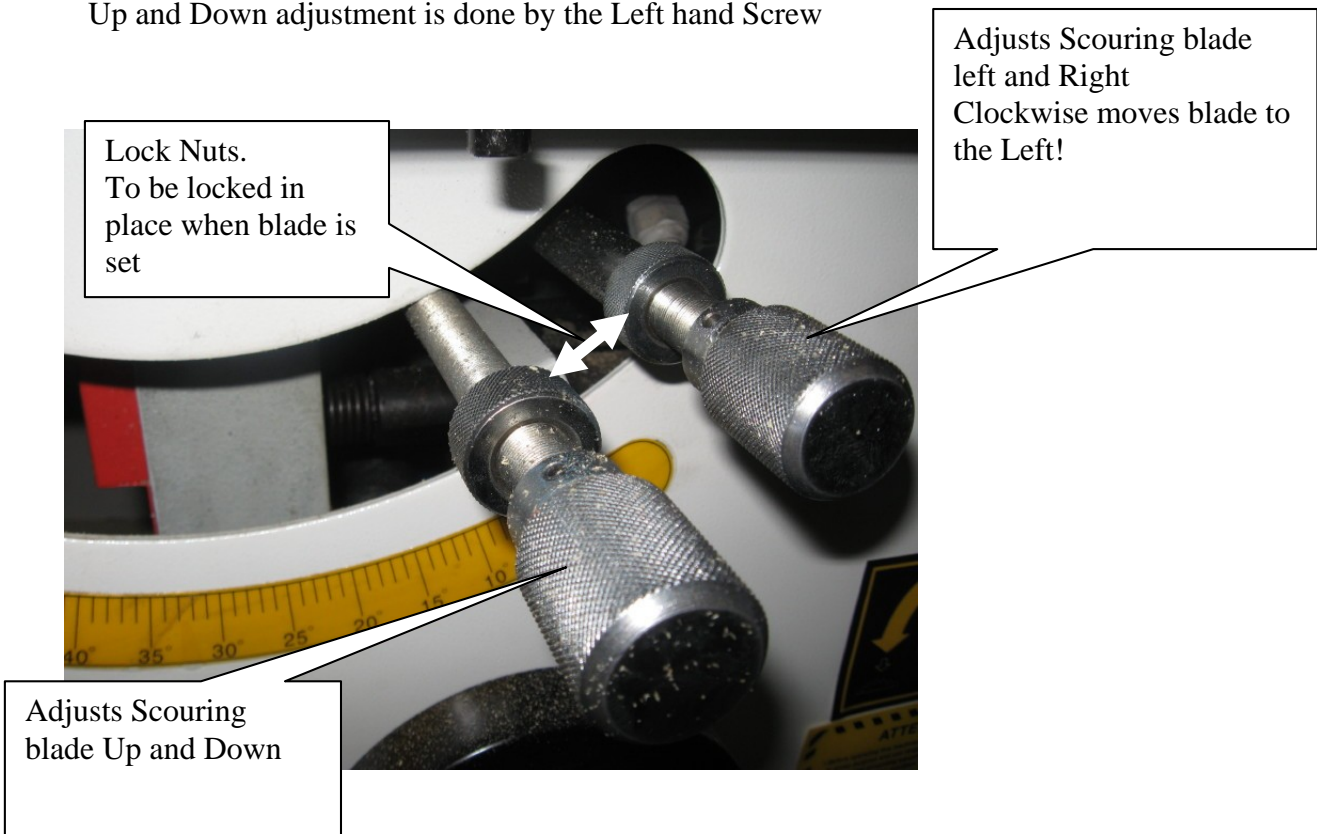

Changing main blade speeds

The main blade has two speeds

Low 3800 RPM (Belts on Pulley blade side)

High 5600 RPM (Belts on Pulley Motor Side)

To change speeds wind the blade all the way down and tilt it to 30 degrees.

(This will give you easier access to change the belt)

Disconnect the power from the machine and open the rear door to the machine base

Loosen the belt tensioning nuts on the tension lever and carefully move both belts over to the set of pulleys required

Below picture is shown set up on Low speed

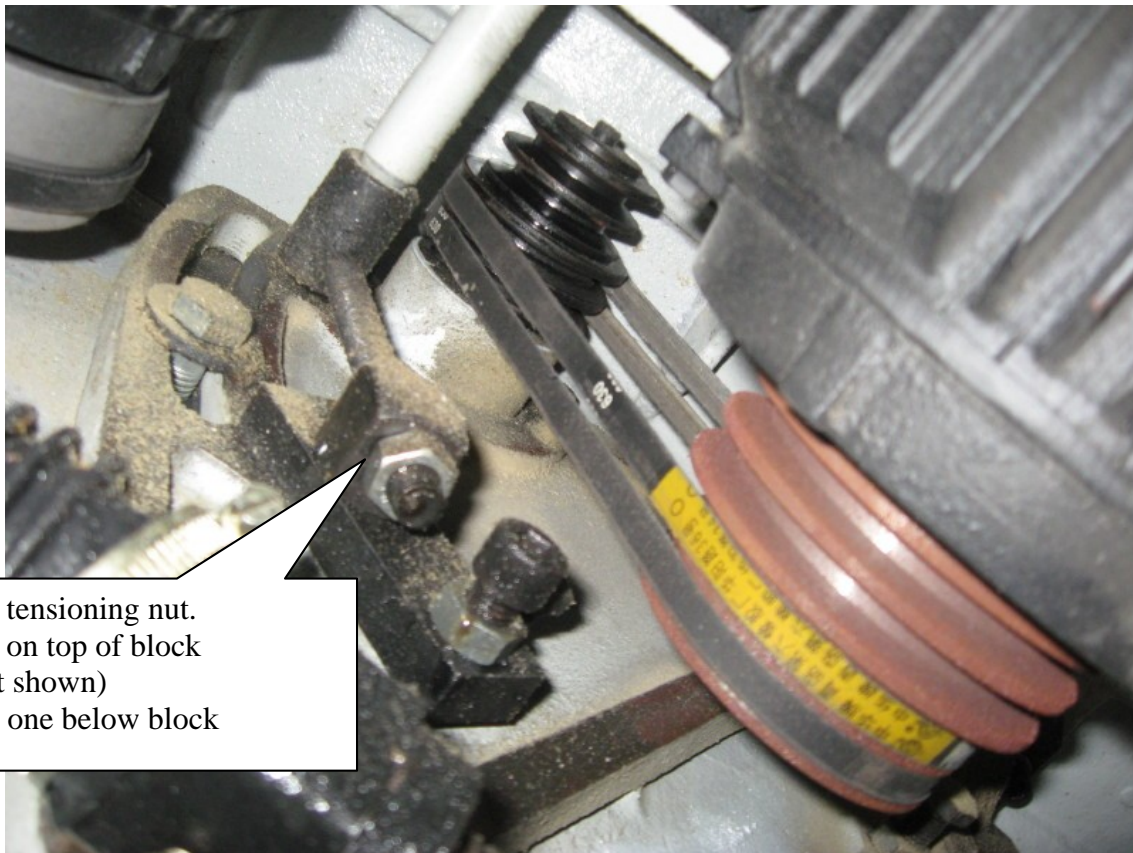

Belt tensioning nut.
One on top of block
(not shown)
and one below block

1.Fixed table and supporting & adjustment mechanism

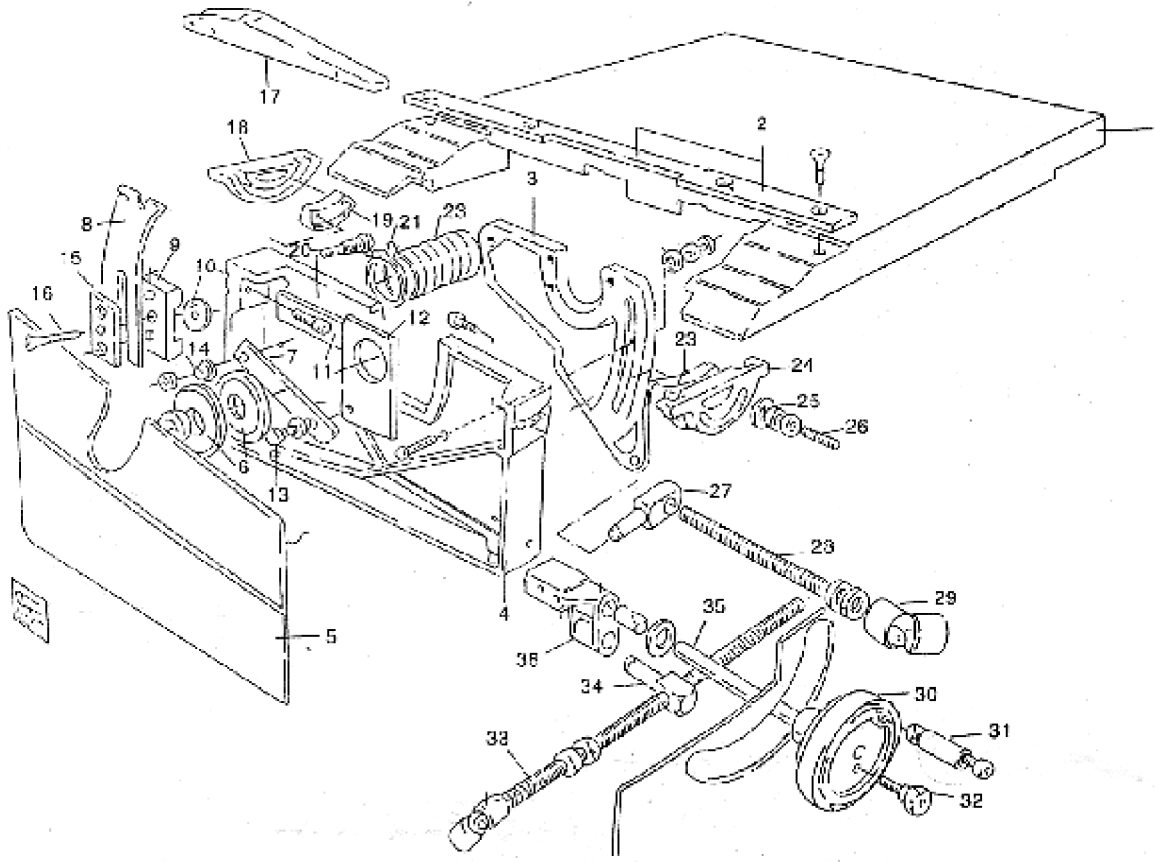

- | | | | |
|-----|----------------------------|-----|------------------------|
| 1, | fixed table | 20, | guide track |
| 2, | protection board | 21, | bolt |
| 3, | lift board | 22, | pipe block |
| 4, | connection board | 23, | dust collection pipe |
| 5, | the cover of anti-dust | 24, | guide track |
| 6, | sawnipping plate | 25, | circumgyrating base |
| 7, | pulling board | 26, | cushion |
| 8, | longitudinal cutting knife | 27, | bolt |
| 9, | fixed board | 28, | lift nut |
| 10, | nut | 29, | lift screw |
| 11, | connection board | 30, | gimbal |
| 12, | following action board | 31, | handwheel |
| 13, | bolt | 32, | handle |
| 14, | cushion | 33, | bolt |
| 15, | plywood | 34, | angle bolt |
| 16, | bolt | 35, | angle nut |
| 17, | protection hood | 36, | lift adjusting spindle |
| 18, | circumgyrating base | 37, | adjusting base |

2 Main saw

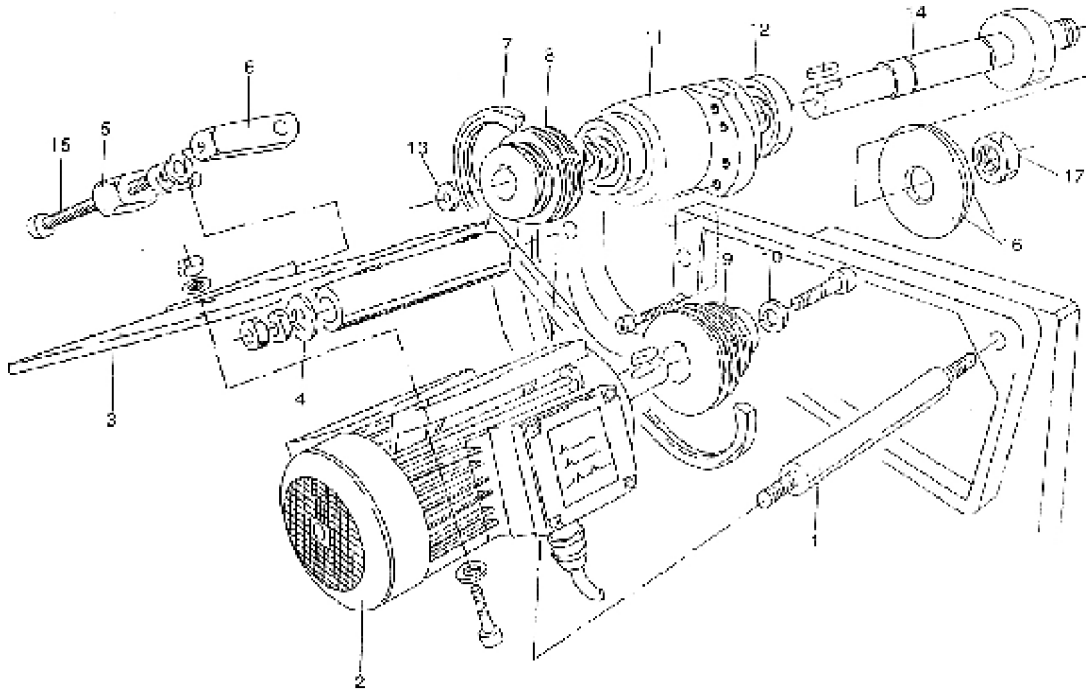

- | | | | |
|----|--------------------|-----|---------------------|
| 1, | motor base spindle | 10, | pressure cushion |
| 2, | motor | 11, | main spindle sheath |
| 3, | motor base | 12, | bearing |
| 4, | cushion | 13, | pressure cushion |
| 5, | connection board | 14, | main spindle |
| 6, | adjusting sheath | 15, | adjusting screw |
| 7, | triangular belt | 16, | saw nip plate |
| 8, | main spindle wheel | 17, | nut |
| 9, | motor wheel | | |

3 Auxiliary saw

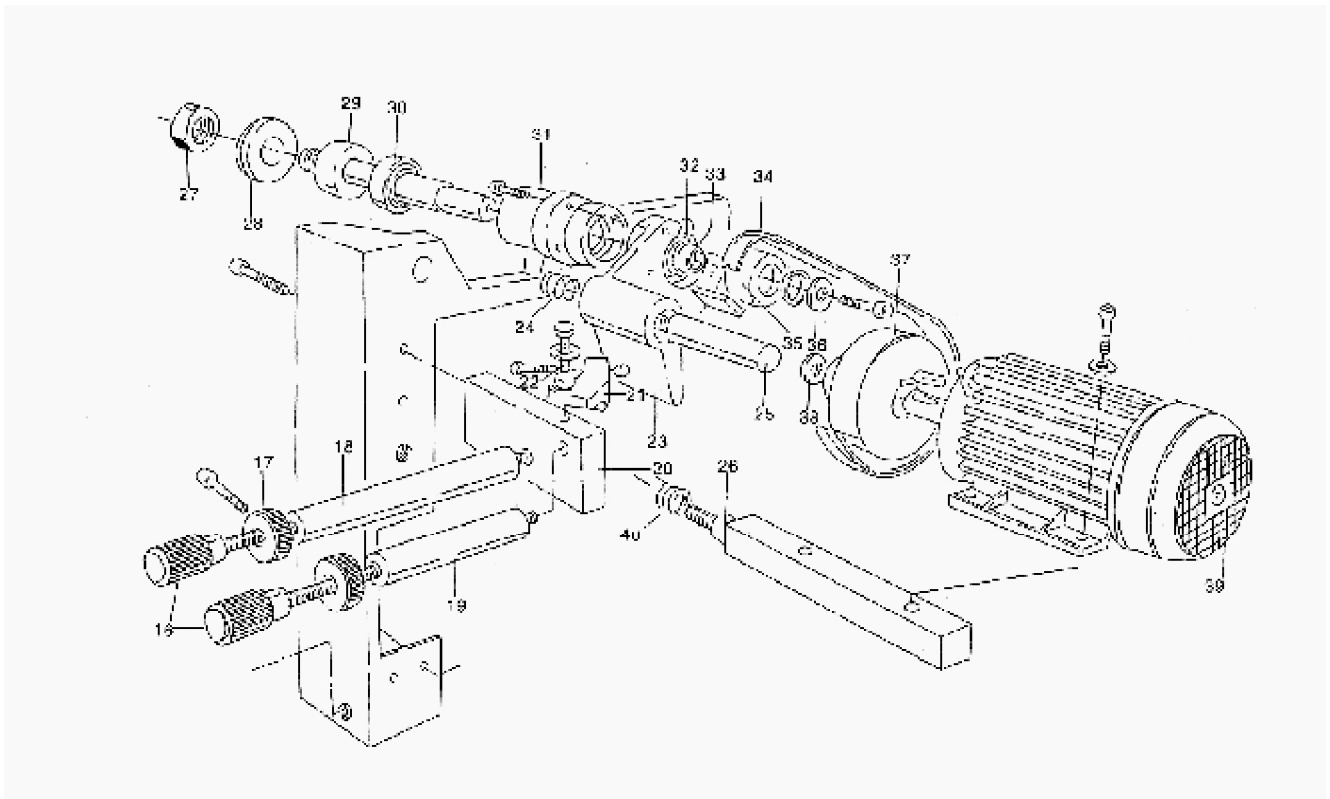

- | | |
|------------------------------|-------------------------|
| 16, inching handle | 29, scoring saw spindle |
| 17, lock nut | 30, bearing |
| 18 fixed sheath | 31, scoring saw sheath |
| 20, fixed base | 32, bearing |
| 21, feeding block | 33, sheath |
| 22, bolt | 34, driving belt |
| 23, scoring saw turning base | 35, scoring saw wheel |
| 24, spring | 36, pressure cushion |
| 25, oriented spindle | 37, motor wheel |
| 26, motor base | 38, pressure cushion |
| 27, nut | 39, motor |
| 28 pressure cushion | 40, torsion spring |

4. Machine body & turning arm

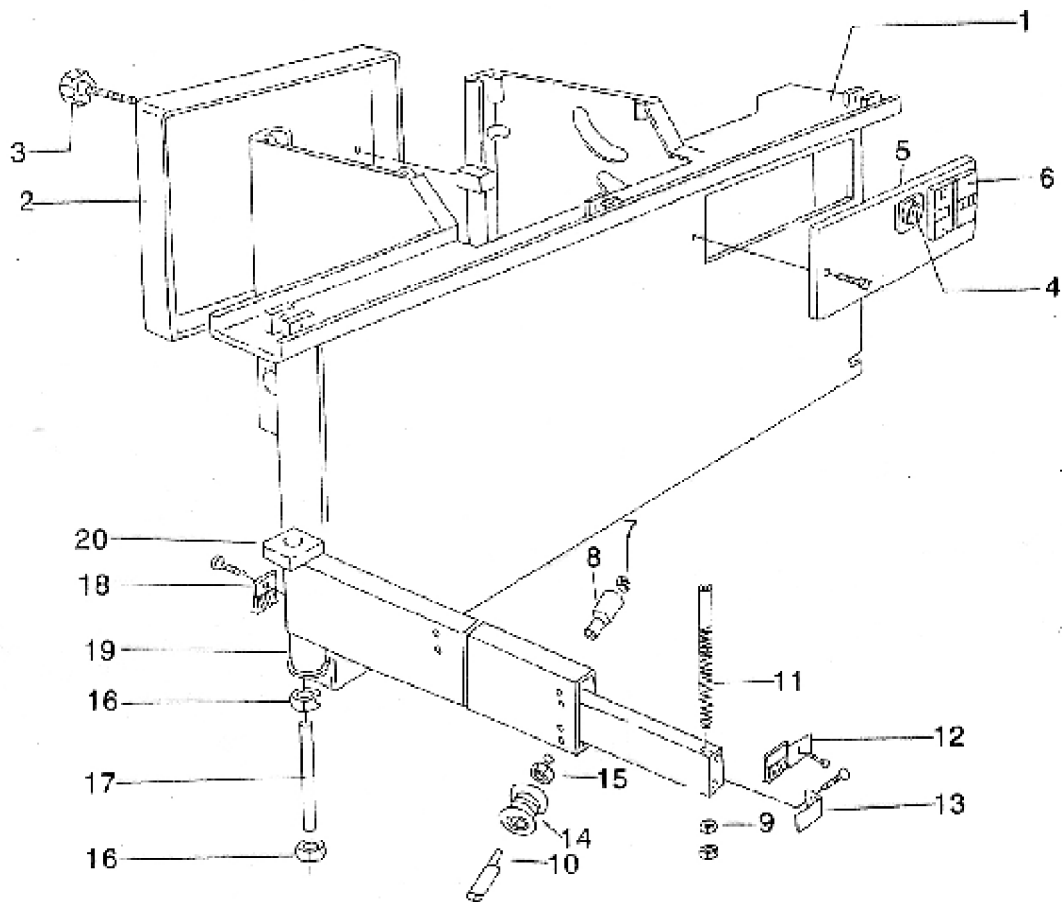

1	machine body	11	adjusting spindle
2	door cover	12	hair brush
3	bolt	13	stop head
4	urgent stop switch	14	roll wheel
5	board base	15	bearing
6	operation button	16	bearing
7	nut	17	spindle of turning arm
8	sheath	18	hair brush
9	nut	19	the pipe of turning arm
10	eccentric spindle	20	lug

5. Bracket

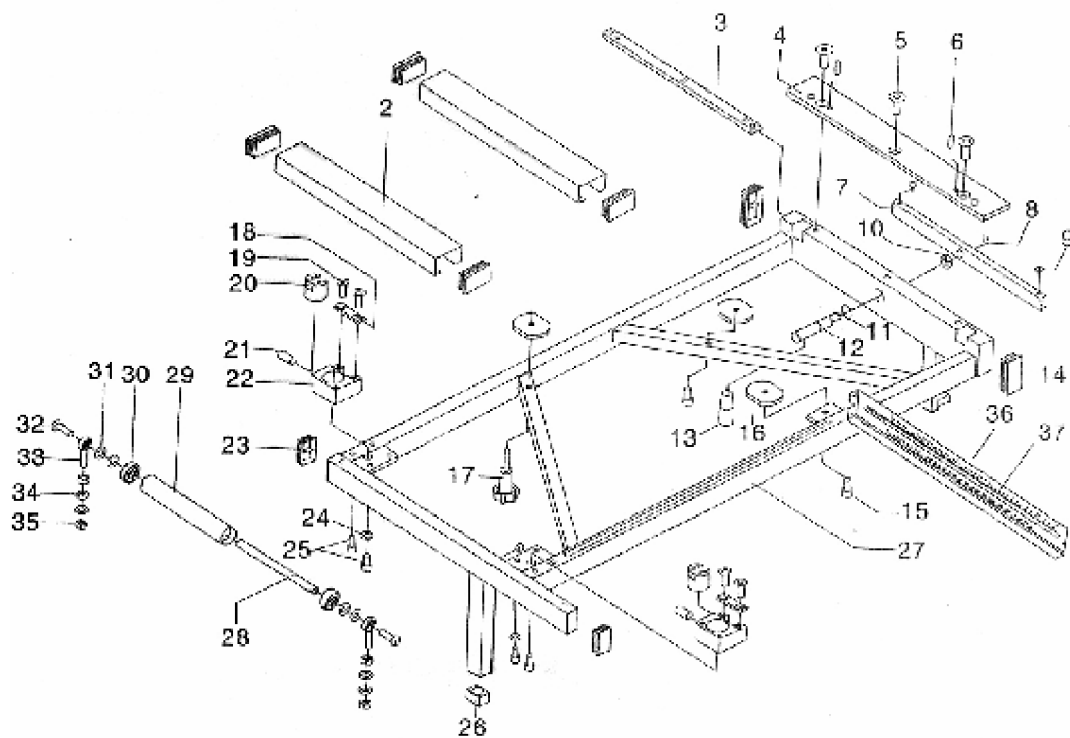

- | | | | |
|-----|------------------------|-----|------------------|
| 1. | Plug | 20. | Adjustment axle |
| 2. | Holding plate | 21. | Limit shaft |
| 3. | Reinforcing plate | 22. | Seat board |
| 4. | V- groove | 23. | Cap |
| 5. | Screw | 24. | Pad |
| 6. | Stabilizer nail | 25. | Stud |
| 7. | Lock block | 26. | Ejector block |
| 8. | Clip | 27. | Bracket |
| 9. | Screw | 28. | Shaft |
| 10. | Pad | 29. | Carriage roller |
| 11. | Pad | 30. | Bearing |
| 12. | Eccentric shaft | 31. | Nut |
| 13. | Handle | 32. | Cap |
| 14. | Plug | 33. | Support |
| 15. | Screw | 34. | Pad |
| 16. | Platen | 35. | Nut |
| 17. | Revolving shaft handle | 36. | Angle scale seat |
| 18. | Pad board | 37. | Angle scale |
| 19. | Screw | | |

6. Crosscut guide plate

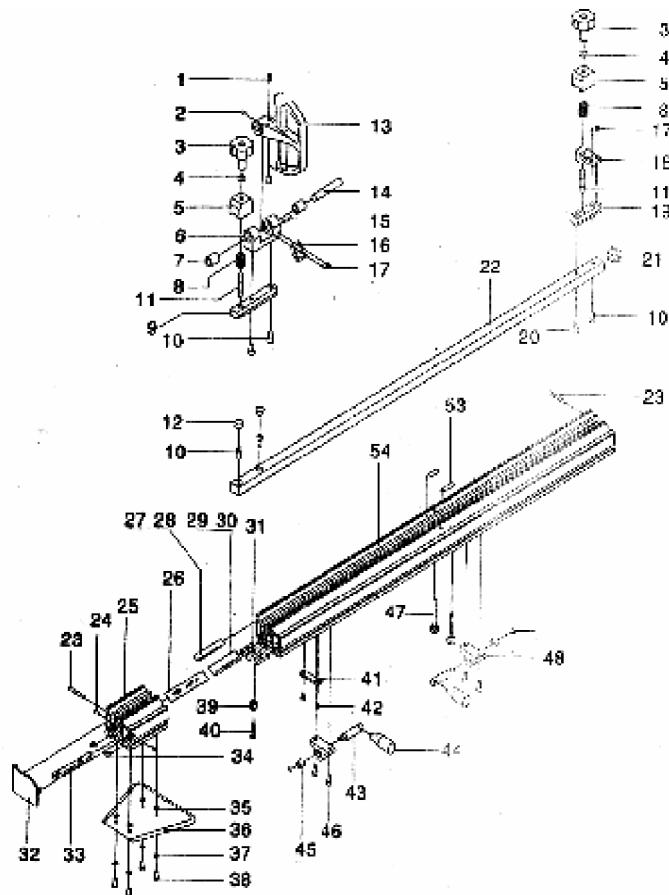

- | | | |
|--------------------|---------------------|---------------------|
| 1. Adjustment bole | 18. Screw | 36. Pad |
| 2. Fixing bolt | 19. Magnifier | 37. Holding plate |
| 3. Locking handle | 20. Fixing block | 38. Pad |
| 4. Pad | 21. Screw bolt | 39. Screw |
| 5. Handle seat | 22. Plug | 40. Sleeve |
| 6. Baffle seat | 23. Draw rod | 41. Screw |
| 7. Copper sleeve | 24. Stabilizer nail | 42. Board |
| 8. Spring | 25. Screw | 43. Screw |
| 9. Fixing block | 25. Extension ruler | 44. Eccentric shaft |
| 10. Screw bolt | 29. Ruler | 45. Handle |
| 11. Shaft | 30. Ruler | 46. Sleeve |
| 12. Plug | 31. Fixing block | 47. Screw |
| 13. Stop board | 32. Plug | 48. Hand screw |
| 14. Shaft | 33. Fixing block | |
| 15. Screw | 34. Nut | |
| 16. Magnifier | | |

7. Straight-cut guide plate

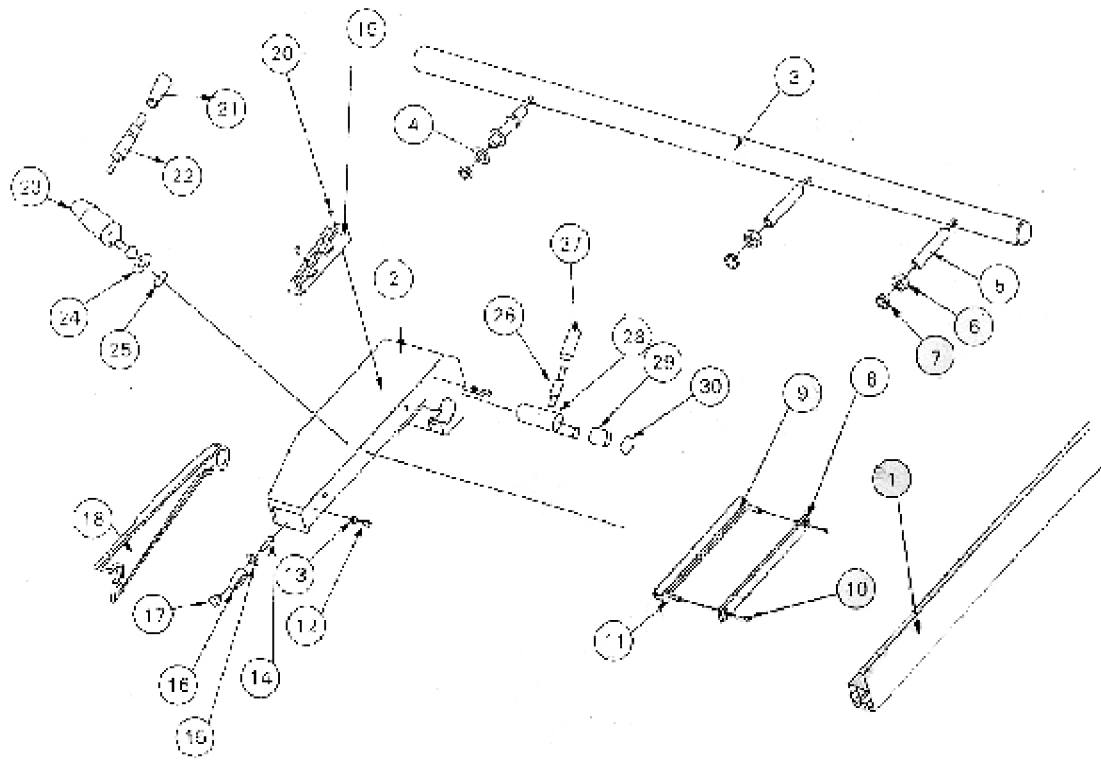

- | | | | |
|----|-----------------------------|----|------------------|
| 1 | Straight-cut guide plate | 16 | Idler wheel |
| 2 | Cam seat (guide plate seat) | 17 | Spacing sleeve |
| 3 | Cam axle (guide shaft axle) | 18 | Push handle |
| 4 | Pad | 19 | Push handle seat |
| 5 | Supporting bolt | 20 | Screw |
| 6 | Screw cap | 21 | Handle |
| 7 | Screw cap | 22 | Handle shaft |
| 8 | Lock plate | 23 | Eccentric shaft |
| 9 | Board | 24 | Pad |
| 10 | Screw | 25 | Clip |
| 11 | Shaft | 26 | Handle shaft |
| 12 | Screw | 27 | Handle |
| 13 | Eccentric sleeve | 28 | Eccentric shaft |
| 14 | Small shaft | 29 | Sleeve |
| 15 | Pad | 30 | Clip |

8、 Sliding table

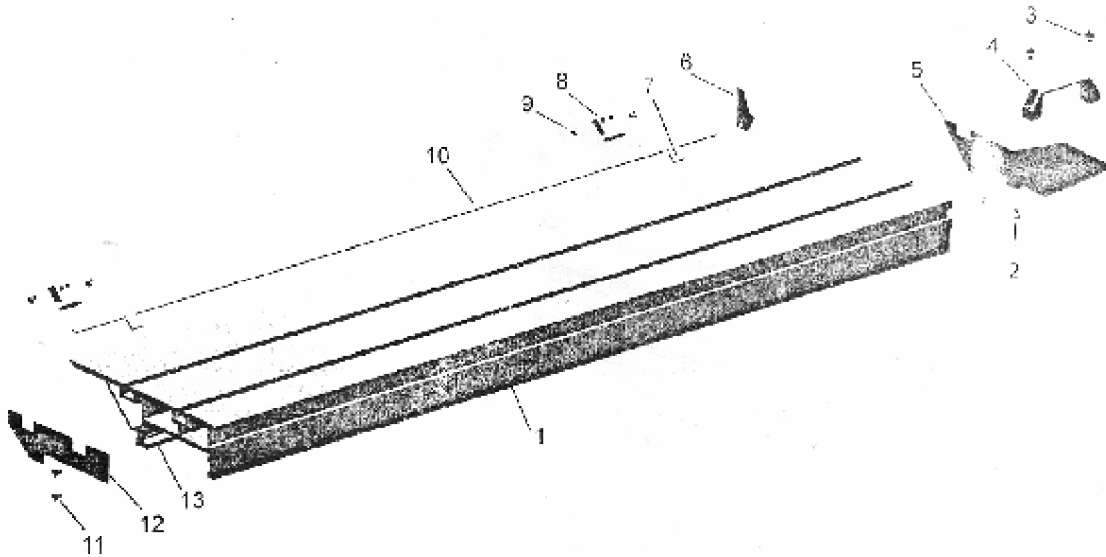

1. Sliding table
2. Screw
3. Screw
4. Handle
5. Handle terminal plate
6. Locking handle
7. Locating plate
8. Fixing block
9. Screw
10. Connecting strip
11. Screw
12. Terminal plate
13. Track metal strip

9 Sliding track seat

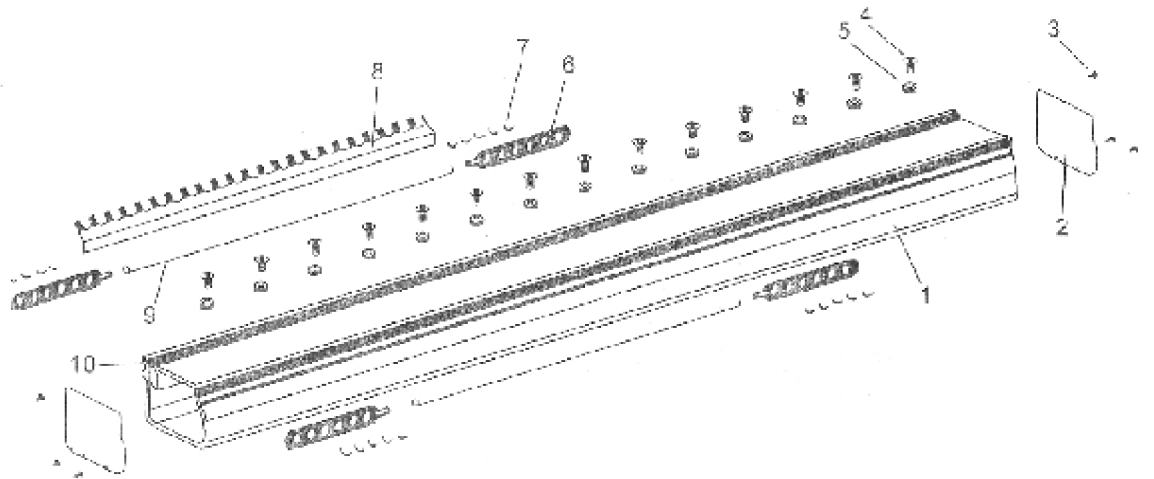

- 1, track seat
- 2, cap
- 3, screw
- 4, adjustment screw bolt
- 5, nut
- 6, keeping bracket
- 7, steel ball
- 8, lock plate
- 9, connecting strip
- 10, track metal strip